

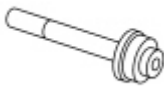



## Rear Wheel Bearing and Axle Shaft Seal

### Special Tool(s)

 <p>ST1326-A</p>	Adapter for 303-224 205-153 (T80T-4000-W)
 <p>ST1541A</p>	Installer, Axle Shaft Bearing 205-124 (T78P-1225-A)
 <p>ST2027-A</p>	Installer, Rear Axle Oil Seal 205-390 (T97T-1177-B)
 <p>ST2035-A</p>	Remover, Axle Bearing 205-219 (T85L-1225-AH)
 <p>ST1185-A</p>	Slide Hammer 100-001 (T50T-100-A)

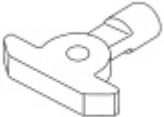
### Material

Item	Specification
Motorcraft® SAE 80W-90 Premium Rear Axle Lubricant XY-80W90-QL (US); CXY-80W90-1L (Canada)	WSP-M2C197- A
Premium Long-Life Grease XG-1-C or XG-1-K (US); CXG-1-C (Canada)	ESA-M1C75-B

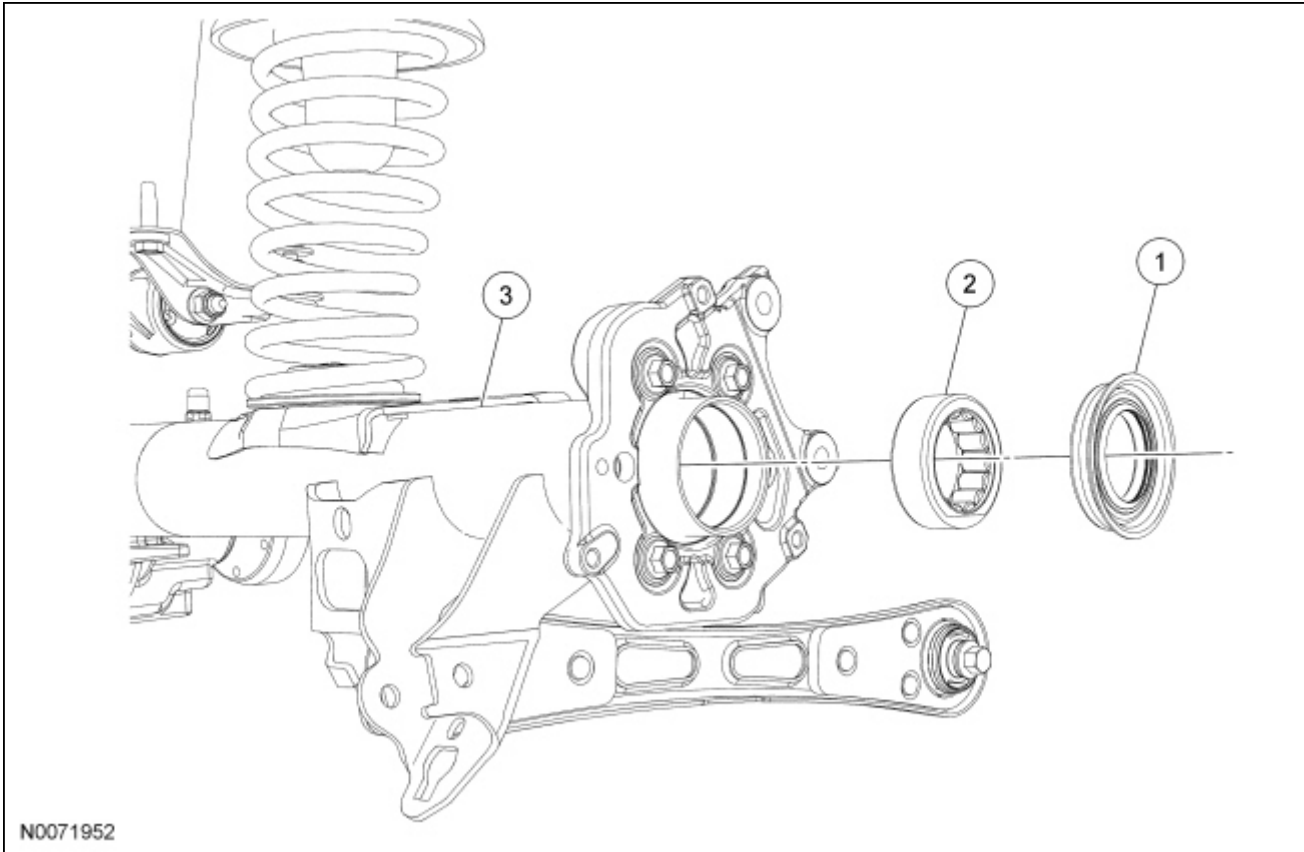

Item	Part Number	Description
1	1177	Axle shaft oil seal
2	1225	Rear axle wheel bearing
3	4010	Axle housing

## Removal

1. Remove the axle shaft. For additional information, refer to [Axle Shaft](#) in this section.
2. **NOTE:** If the axle shaft oil seal is leaking, the axle housing vent may be plugged.

Using the Slide Hammer and Axle Bearing Remover, remove the rear wheel bearing and axle shaft oil seal.

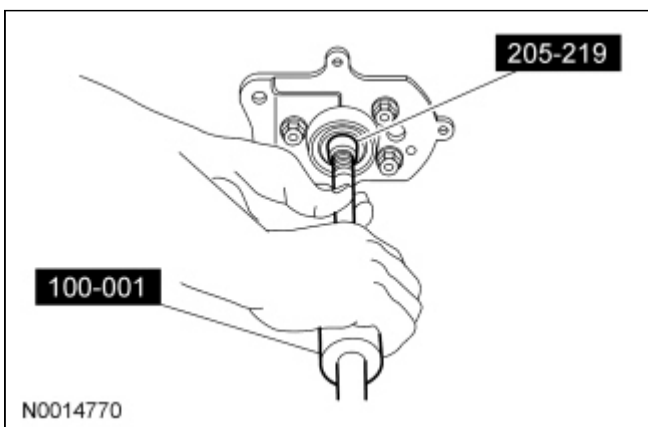

## Installation

1. Lubricate the new rear wheel bearing with the axle lubricant.
2. Using the Axle Shaft Bearing Installer and Adapter, install the new rear wheel bearing.

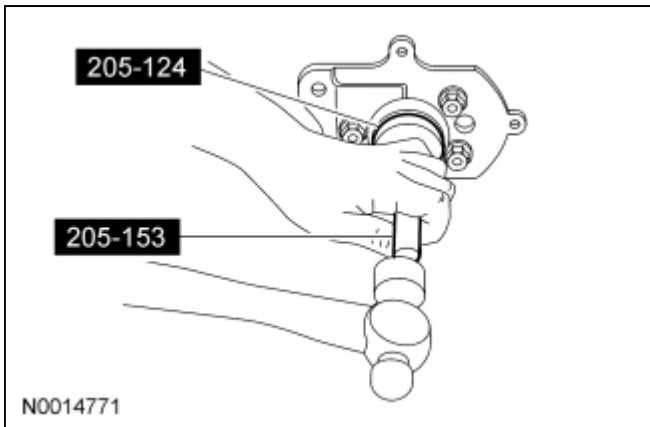

3. Lubricate the lip of the new axle shaft oil seal with grease.
4. Using the Rear Axle Oil Seal Installer and Adapter, install the new axle shaft oil seal.

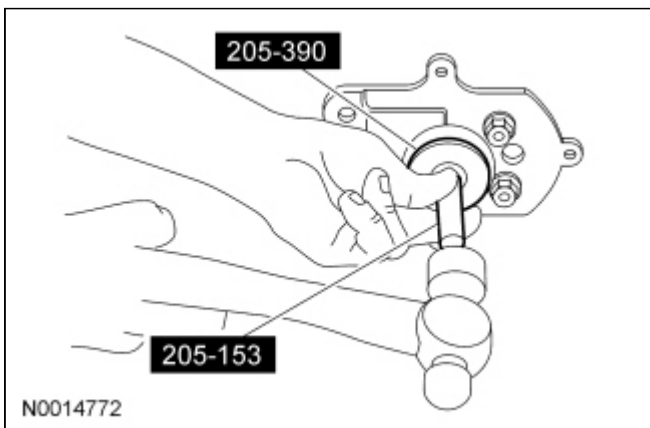

5. Install the axle shaft. For additional information, refer to [Axle Shaft](#) in this section.
-

